

ARNETOLI MOTOR®

**ELECTRIC TRIMMER
ET 1000**



FULL AUTOMATIC

ENGINE BODY DETAIL

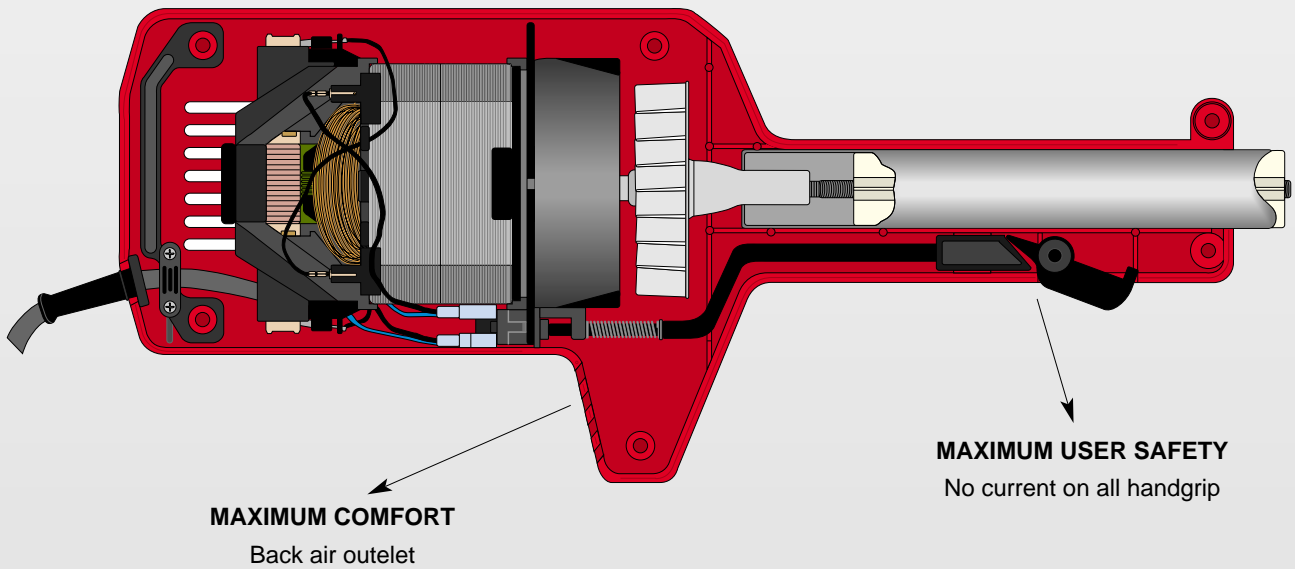

CUTTING HEAD DETAIL

KZ2TS

"TRI-SYSTEM" FULL AUTOMATIC HEAD

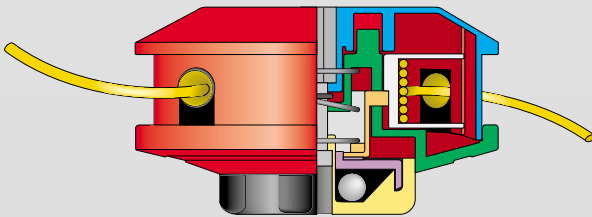

Thanks to its triple line extension system (Automatic Tri-System, Bump-N-Go, Manual), it guarantees fast, efficient and long lasting work, without the user's intervention.

KZ2BV

"BUMP-N-GO" AUTOMATIC HEAD

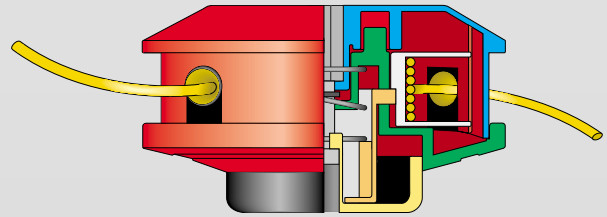

Thanks to its double line extension system (Bump-N-Go and Manual), it is easy to use and guarantees an excellent performance.

TECHNICAL SPECIFICATIONS

Engine type	Electric					
Feeding	220-240 V — ~ 50 Hz					
Cutting head	2-line automatic "Tri-System" or 2-line automatic "Tap-N-Go"					
RPM of cutting head	9.000					
Rotation	Left					
Maximum cutting diam.	370 mm					
Power (Watt)	1000	1100	1200	1300	1400	1500
Line diam.	2,0 mm			2,4 mm		
Weight (approx.)	4,7 Kg.			4,9 Kg.		

ET1000 ACCESSORIES

STANDARD EQUIPMENT

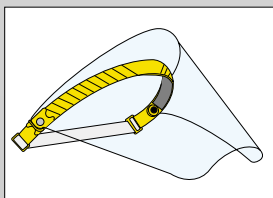

OPTION

